



Low Noise Amplifier 0.9GHz~1.3GHz

Features

- Gain: 39dB Typical
- Noise Figure: 1.2dB Typical
- P1dB Output Power: +26dBm Typical
- Supply Voltage: +12V @ 310mA
- 50 Ohm Matched Input / Output
- Size: 1.77x 1.06" x 0.39"



Typical Applications

- Wireless Infrastructure
- 5G communication
- Test and measurement Instrument

RF Microwave & VSAT
Fiber Optics

Parameter	Min.	Typ.	Max.	Units
Frequency Range	0.9		1.3	GHz
Gain	37	39		dB
Gain Flatness		±0.5	±1.0	dB
Gain Variation Over Temperature(-40 ~ +85)		±1.0		dB
Noise Figure		1.2	1.5	dB
Input VSWR		1.8	2.0	: 1
Output VSWR		1.8	2.0	: 1
Output 1dB Compression Point (P1dB)	25	26		dBm
Saturated Output Power (Psat)		27		dBm
Output Third Order Intercept (OIP3)		35		dBm
Isolation S12		-55		dB
Supply Current (I _{dd}) (V _{cc} =+12V)		300	350	mA

Weight	1.06 ounces	Impedance	50ohms
Input /Output Connectors	SMA-Female	Material	Aluminum
Finish	Gold Plated	Package Sealing	Epoxy Sealed (Standard)
			Hermetically Sealed (Option with extra charge)



Absolute Maximum Ratings

Operating Voltage	+12V±10%
RF Input Power	-8dBm

Biassing Up Procedure

Step 1	Connect Ground Pin
Step 2	Connect input and output
Step 3	Connect +12V biasing

Power OFF Procedure

Step 1	Turn off +12V biasing
Step 2	Remove RF connection
Step 3	Remove Ground

Environmental Specifications

Operational Temperature	-40°C~+85°C
Storage Temperature	-50°C~+105°C
Altitude	30,000 ft. (Epoxy Sealed Controlled environment)
	60,000 ft. 1.0psi min (Hermetically Sealed Un-controlled environment) (Optional)
Vibration	25g RMS (15 degrees 2KHz) endurance, 1 hour per axis
Humidity	100% RH at 35°C, 95%RH at 40°C
Shock	20G for 11msec half sine wave, 3 axis both directions

All Dimensions in mm (inches)

Heat Sink required during operation(Sold Separately)

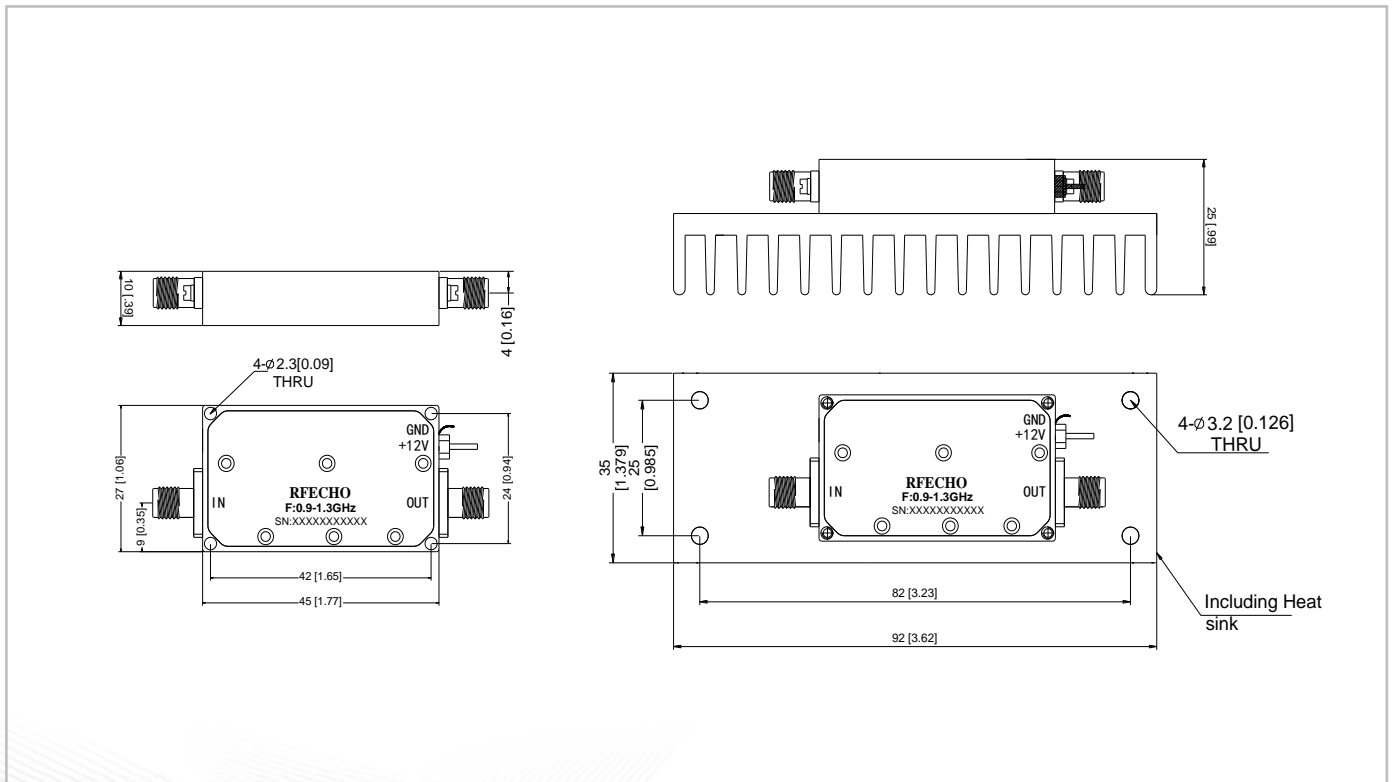



Gain

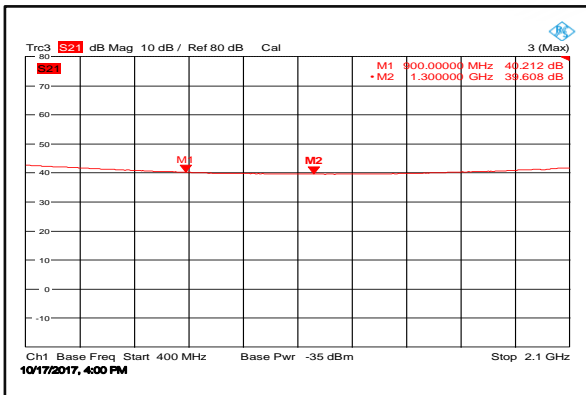

Input VSWR

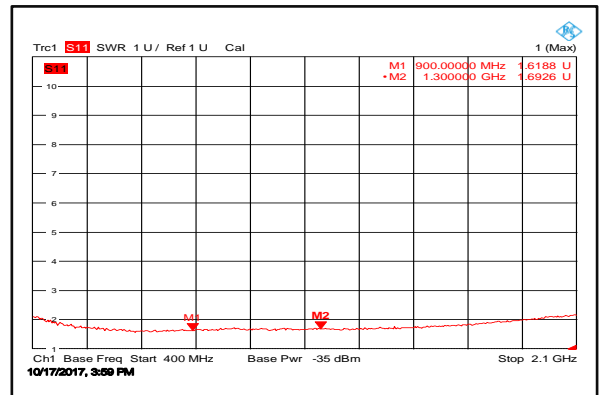

Output VSWR

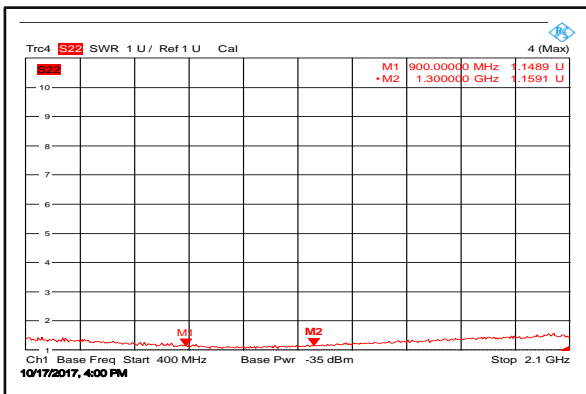

Isolation

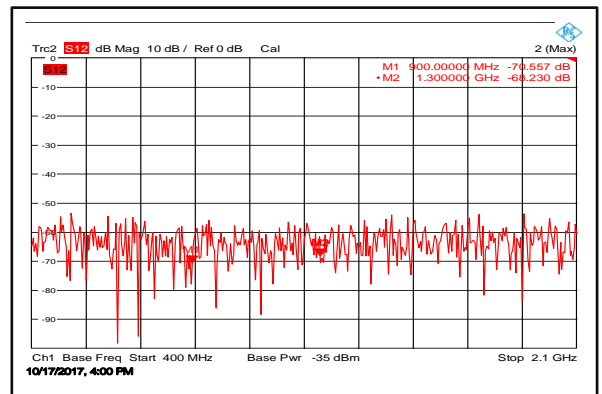

Gain vs. Output Power

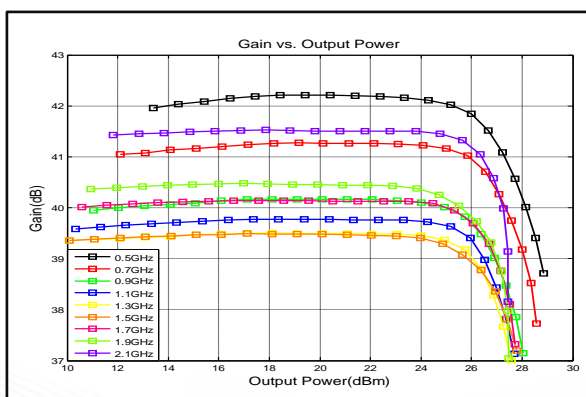

P1dB vs. Frequency

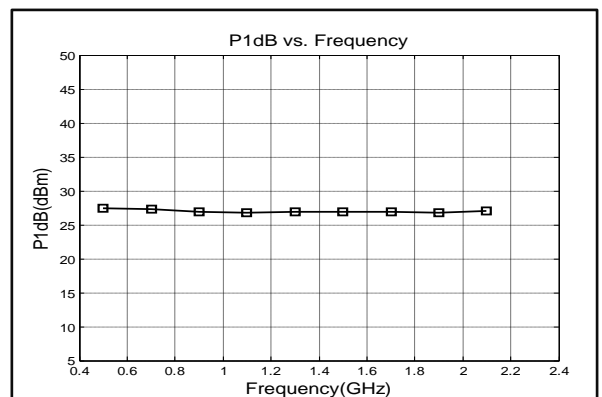



Output Third Order Intercept (OIP3)

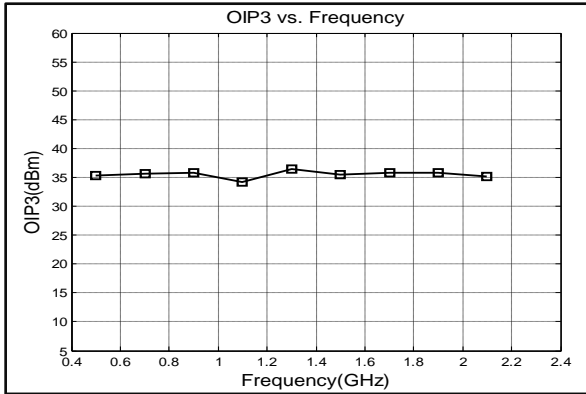

Noise Figure

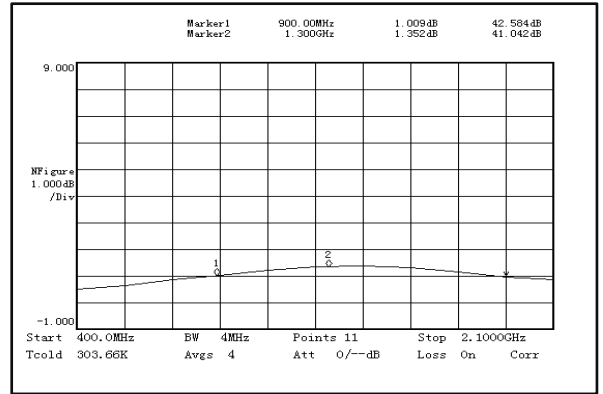

2nd Harmonic Wave Output Power

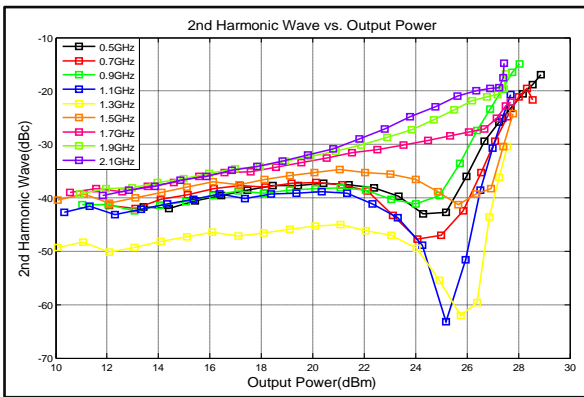

3rd Harmonic Wave Output Power

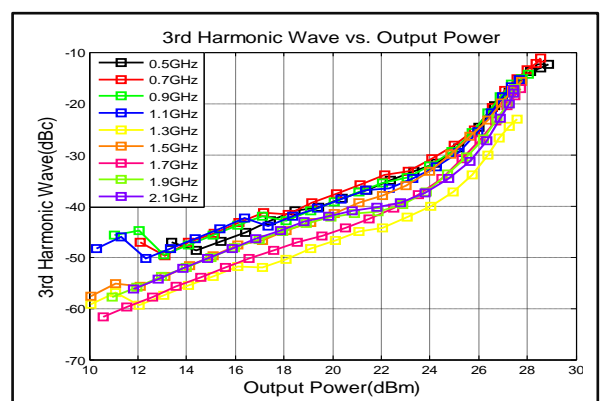

4th Harmonic Wave Output Power

