



Low Noise Amplifier 4.8GHz~6GHz



Features

- Gain: 15dB Typical
- Noise Figure: 1.5dB Typical
- P1dB Output Power: +18dBm Typical
- Supply Voltage: +5V

Typical Applications

- Wireless Infrastructure
- 5G communication
- Test and measurement Instrument

RF Microwave & VSAT
Fiber Optics

Parameter	Min.	Typ.	Max.	Min.	Typ.	Max.	Units
Frequency Range	4.8		5.4	5.4		6	GHz
Gain	14	16		13.5	15		dB
Gain Flatness		±0.25			±0.5		dB
Gain Variation Over Temperature (-40°C~+85°C)		±0.5			±0.5		dB
Noise Figure		1.5	1.8		1.5	1.8	dB
Input VSWR		1.5	1.8		1.5	1.8	: 1
Output VSWR		1.5	1.8		1.7	2.0	: 1
Output Power for 1 dB Compression (P1dB)	15	17		15	18		dBm
Saturated Output Power (Psat)		18			19		dBm
Output Third Order Intercept (OIP3)		28			28		dBm
Supply Current (Vcc=+5V)		75	100		75	100	mA
Isolation S12		-30			-27		dB

Weight	0.5 Max. ounces(Net)	Impedance	50ohms
	1.0 Max. ounces(Including Heat sink)		
Input /Output Connectors	SMA-Female	Material	Aluminum
Finish	Gold Plated	Package Sealing	Epoxy Sealed (Standard)
			Hermetically Sealed (Optional)



Absolute Maximum Ratings

Operating Voltage	5.5V
RF Input Power (RFIN)(Vcc= +5V)	+20dB m

Biasing Up Procedure

Step 1	Connect Ground Pin
Step 2	Connect input and output
Step 3	Connect +5V biasing

Power OFF Procedure

Step 1	Turn off +5V biasing
Step 2	Remove RF connection
Step 3	Remove Ground

Environmental Specifications

Operational Temperature	-40°C~+85°C
Storage Temperature	-50°C~+105°C
Altitude	30,000 ft. (Epoxy Sealed Controlled environment)
	60,000 ft. 1.0psi min (Hermetically Sealed Un-controlled environment) (Optional)
Vibration	25g RMS (15 degrees 2KHz) endurance, 1 hour per axis
Humidity	100% RH at 35°C, 95%RH at 40°C
Shock	20G for 11msec half sine wave, 3 axis both directions

Outline Drawing:

All Dimensions in mm (inches)
Housing Tolerances ± 0.1 (0.004)

Heat Sink required during operation(Sold Separately)

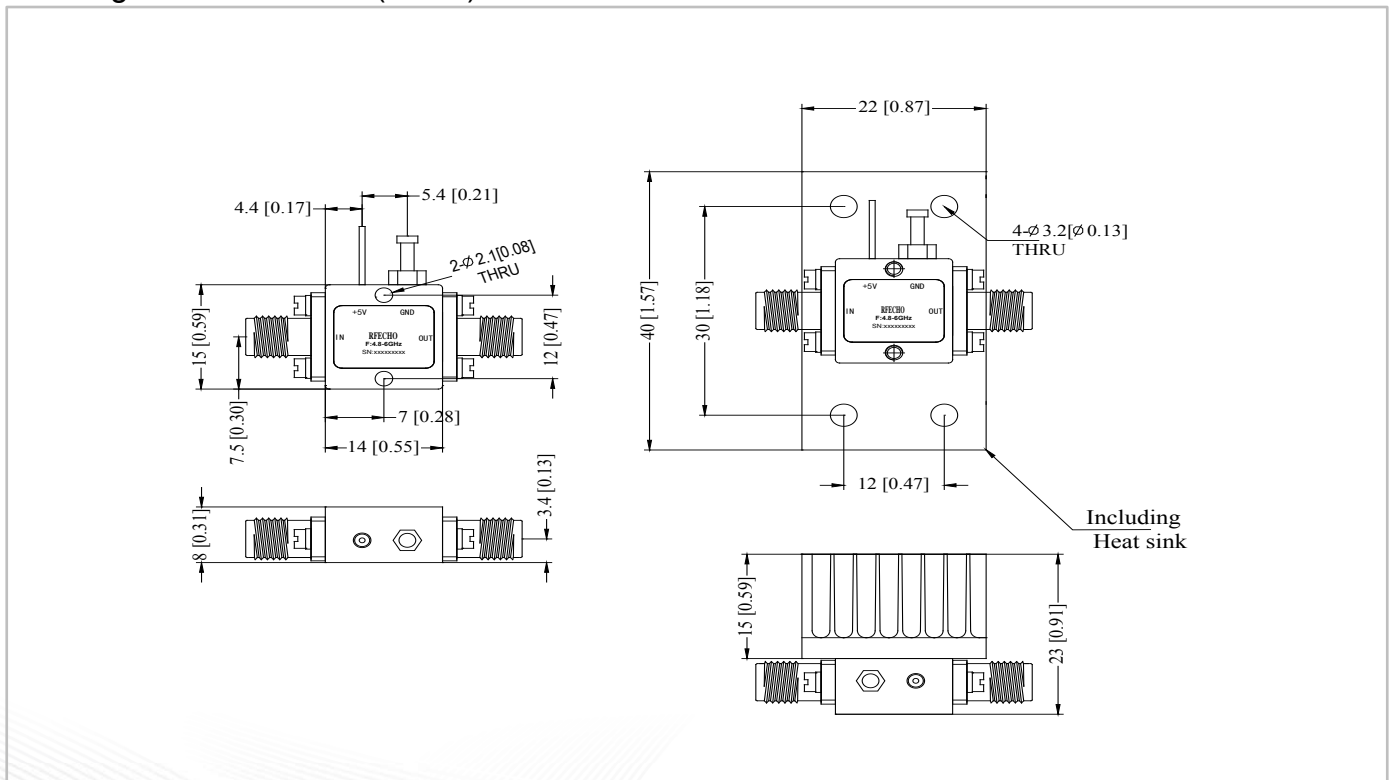



Gain@+25°C

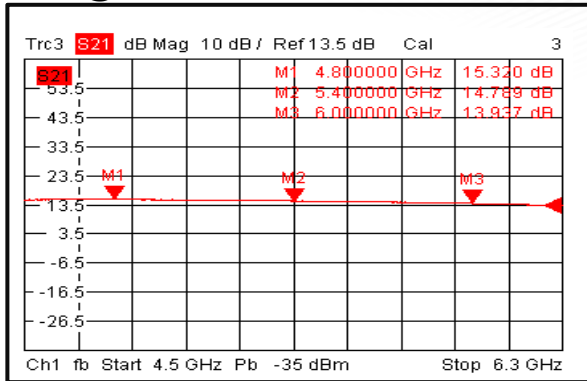

Input VSWR@+25°C

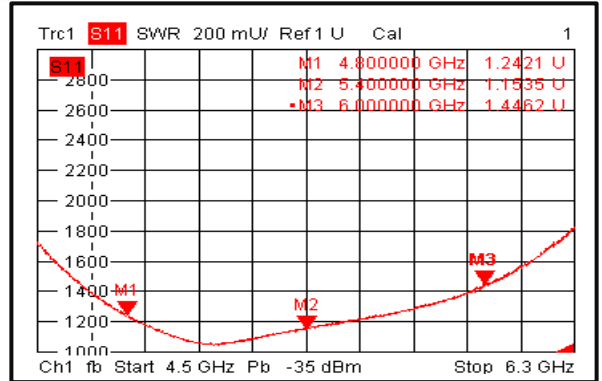

Output VSWR@+25°C

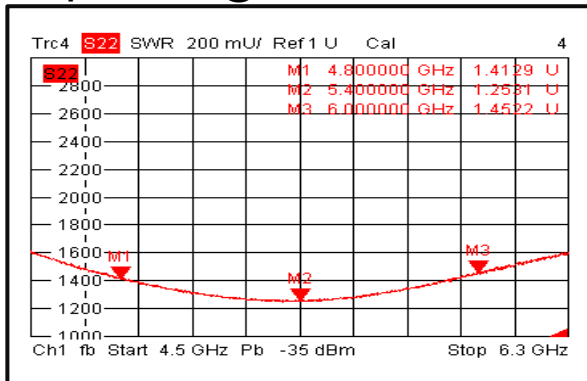

Isolation@+25°C

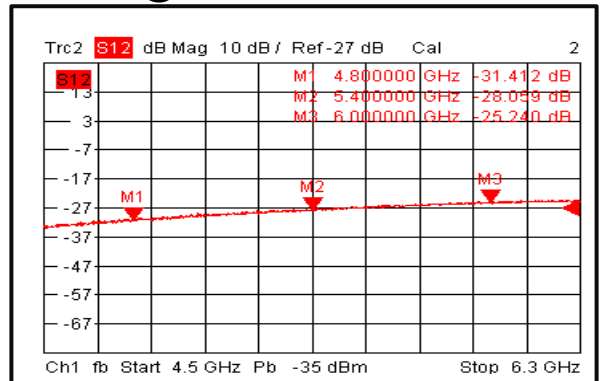

Gain@-40°C

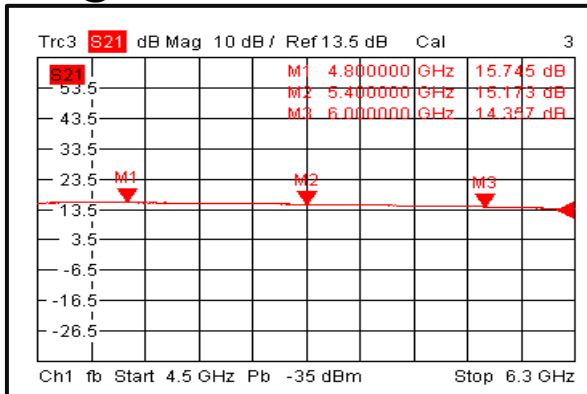

Input VSWR@-40°C

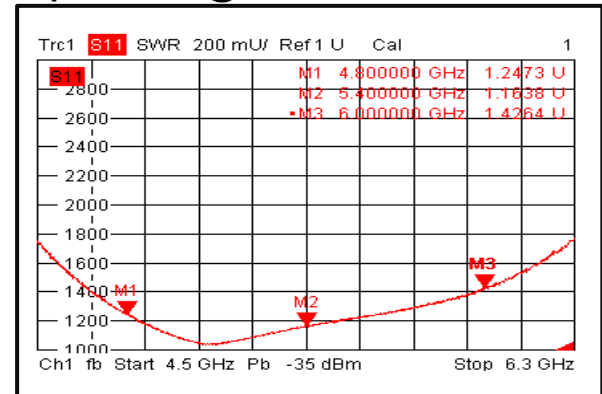

Output VSWR@-40°C

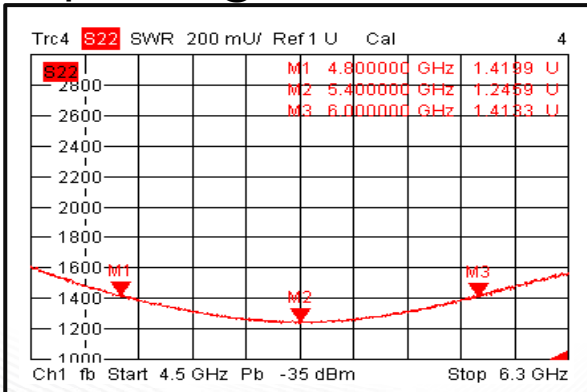

Isolation@-40°C

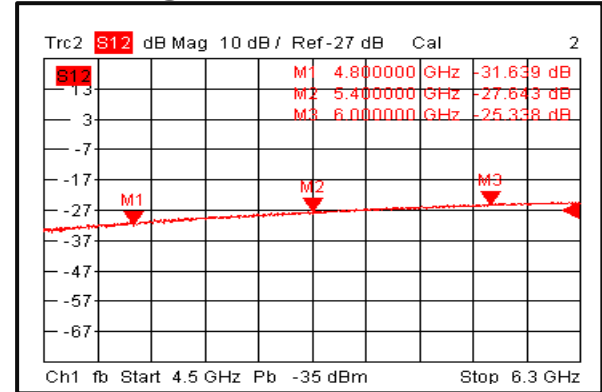



Gain@+85°C

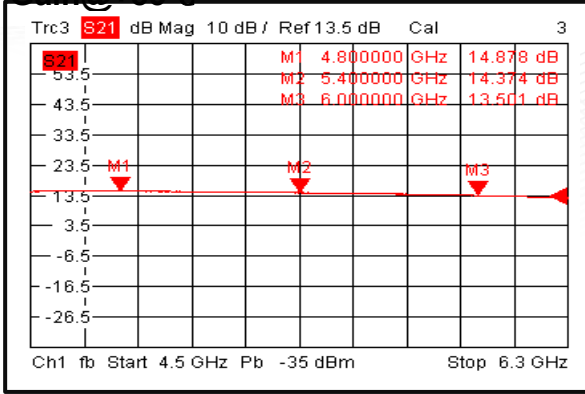

Input VSWR@+85°C

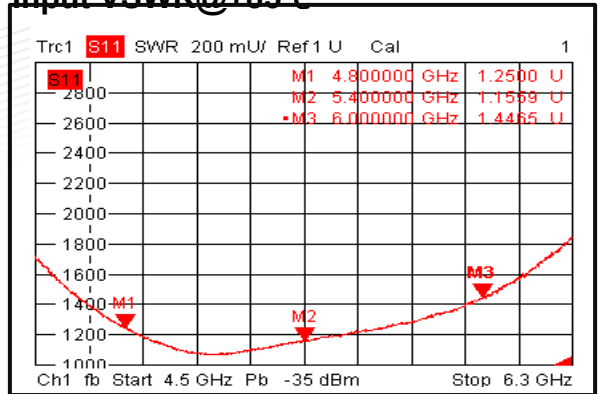

Output VSWR@+85°C

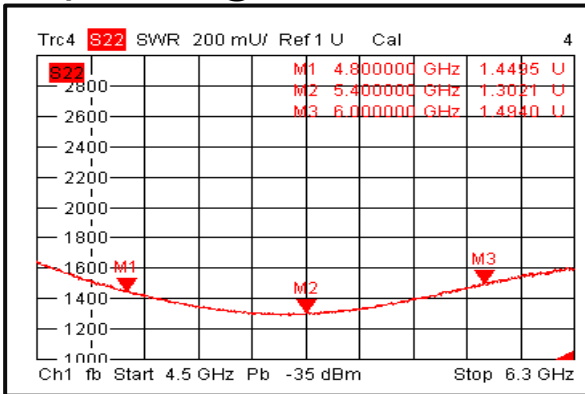

Isolation@+85°C

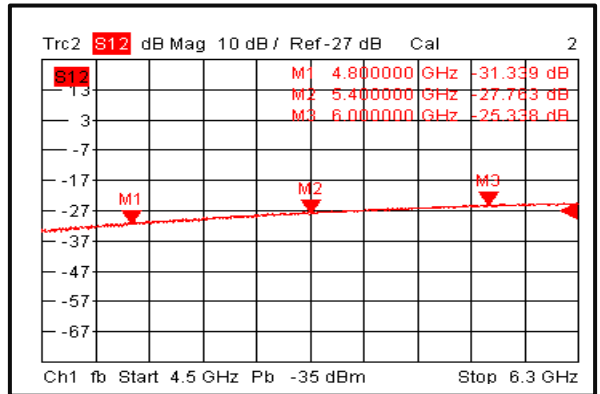

Gain vs. Output Power

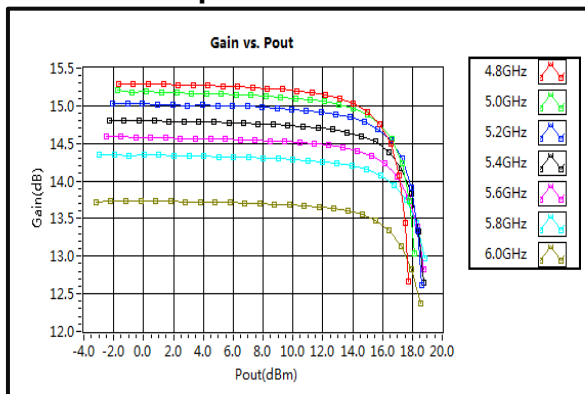

P1dB vs. Frequency

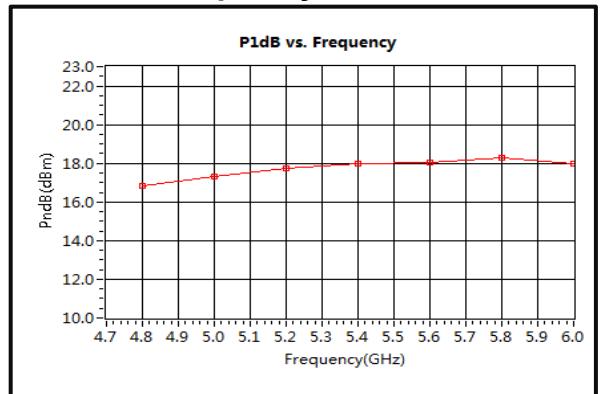

Output Third Order Intercept (OIP3)

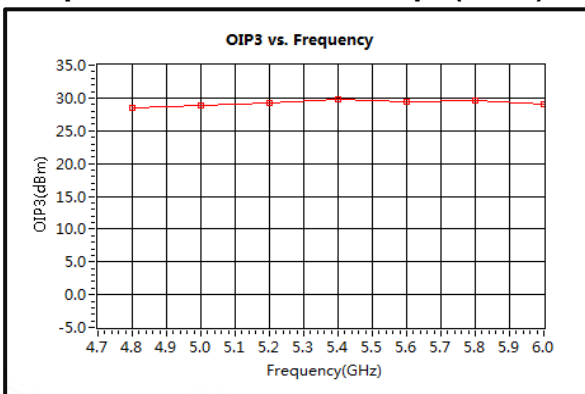

Saturation Power vs. Frequency

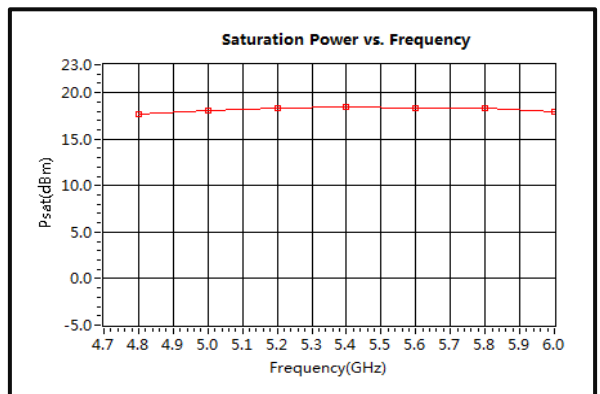



Noise Figure

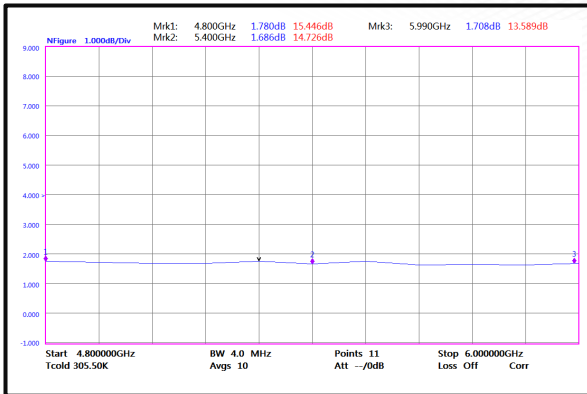

2nd Harmonic Wave Output Power

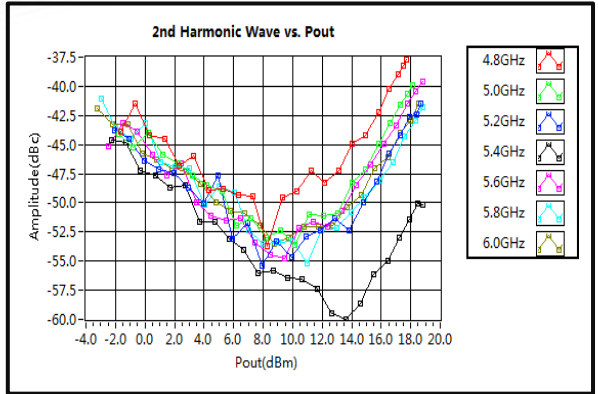

3rd Harmonic Wave Output Power

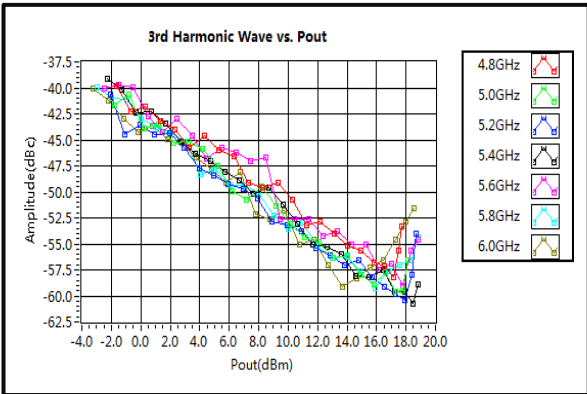

4th Harmonic Wave Output Power

