



# Ultra Wide Band Low Noise Amplifier 0.01GHz~54GHz

## Features

- Gain: 36 dB Typical
- Noise Figure: 4.0dB Typical
- P1dB Output Power: 13dBm Typical
- Supply Voltage: +12V @280mA
- 50 Ohm Matched



## Typical Applications

- Wireless Infrastructure
- 5G communication
- Test and measurement Instrument

RF Microwave & VSAT  
Fiber Optics

Parameter	Min.	Typ.	Max.	Min.	Typ.	Max.	Min.	Typ.	Max.	Units
Frequency Range	0.01		26.5	26.5		40	40		54	GHz
Gain	31	37	40	28	35	38	12	28		dB
Gain Flatness		±2.0			±2.0			±9		dB
Gain Variation Over Temperature (-40°C~+85°C)		±2.0			±1.0			±2.5		dB
Noise Figure		4.0	6.5		5.5	8.5		8.5		dB
Input VSWR		1.5			1.8			2.6		:1
Output VSWR		1.5			1.8			2.0		:1
Output Power for 1 dB Compression (P1dB)	10	14		8	11			8		dBm
Saturated Output Power (Psat)		15			12			9		dBm
Output Third Order Intercept (OIP3)		21			20			16		dBm
Supply Current (Idd) (Vcc=+12V)		280	350		280	350		280	350	mA
Isolation S12		-65			-55			-45		dB

Weight	0.9ounces (Max.)	Impedance	50ohms
Input /Output Connectors	2.4mm-Female	Material	Aluminum
Finish	Gold Plated	Package Sealing	Epoxy Sealed (Standard)
			Hermetically Sealed (Option with extra charge)



### Absolute Maximum Ratings

Operating Voltage	+15V
RF Input Power (RFIN)	-13dBm

### Biasing Up Procedure

Step 1	Connect Ground Pin
Step 2	Connect input and output
Step 3	Connect +12V biasing

### Power OFF Procedure

Step 1	Turn off +12V biasing
Step 2	Remove RF connection
Step 3	Remove Ground

### Environmental Specifications

Operational Temperature	-40°C~+85°C
Storage Temperature	-50°C~+105°C
Altitude	30,000 ft. (Epoxy Sealed Controlled environment)
	60,000 ft. 1.0psi min (Hermetically Sealed Un-controlled environment) (Optional)
Vibration	25g RMS (15 degrees 2KHz) endurance, 1 hour per axis
Humidity	100% RH at 35°C, 95%RH at 40°C
Shock	20G for 11msec half sine wave, 3 axis both directions

### Outline Drawing:

All Dimensions in mm (inches)

Heat Sink required during operation(Sold Separately)

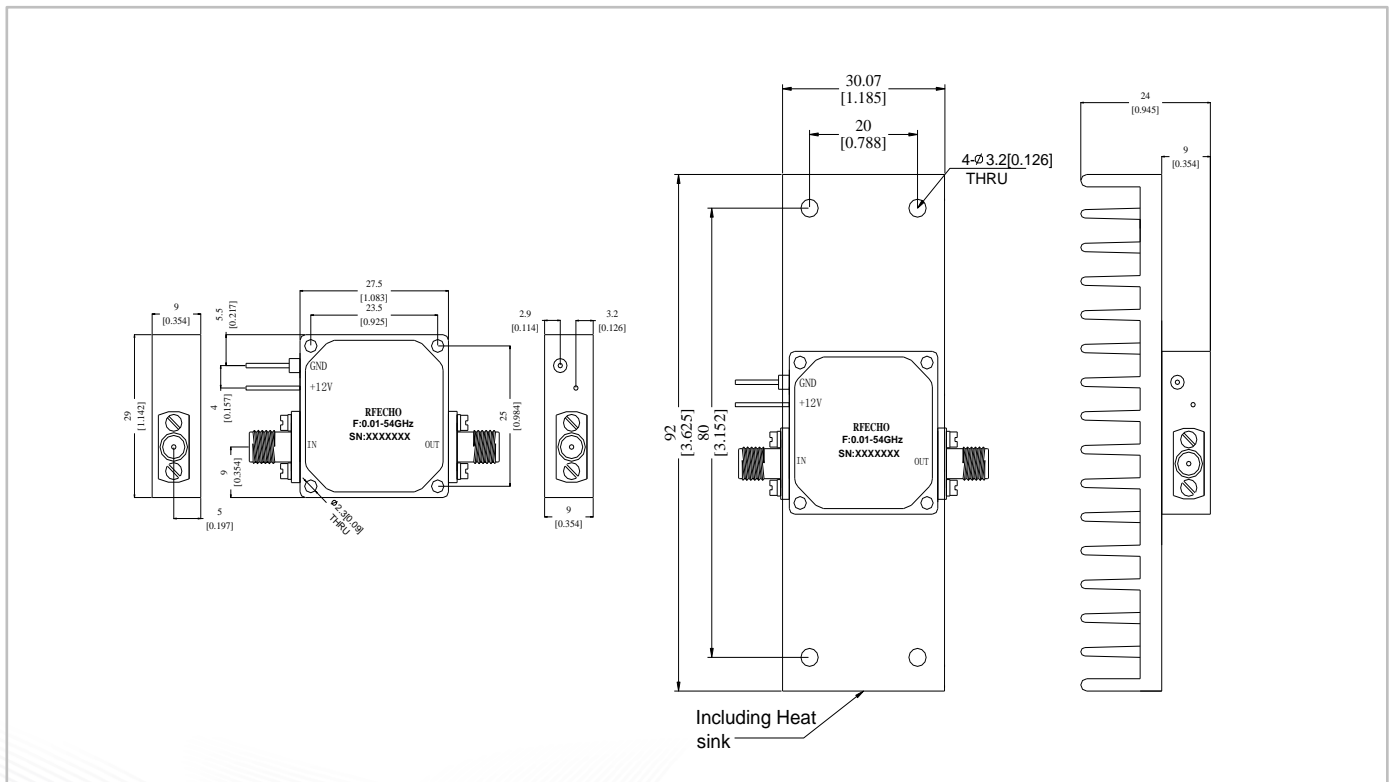



### Gain @ +25°C

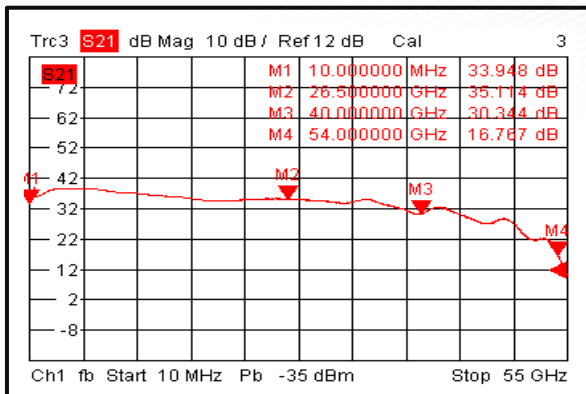

### Input VSWR @ +25°C

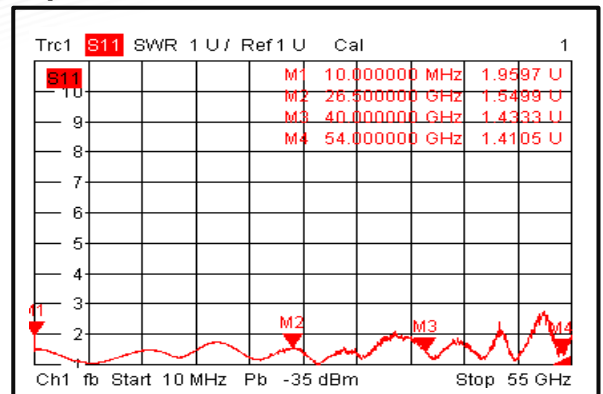

### Output VSWR @ +25°C

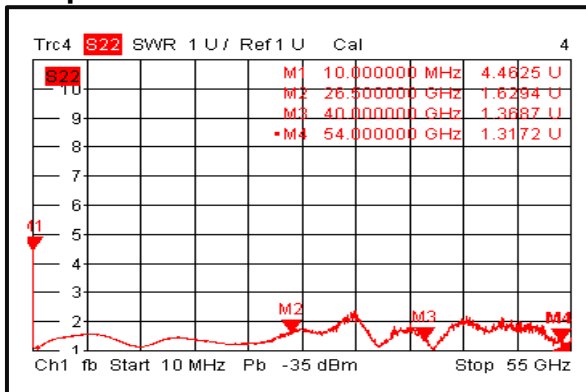

### Isolation @ +25°C

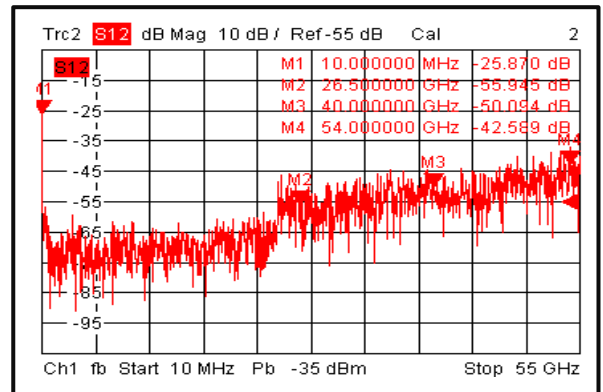

### Gain @ -40°C

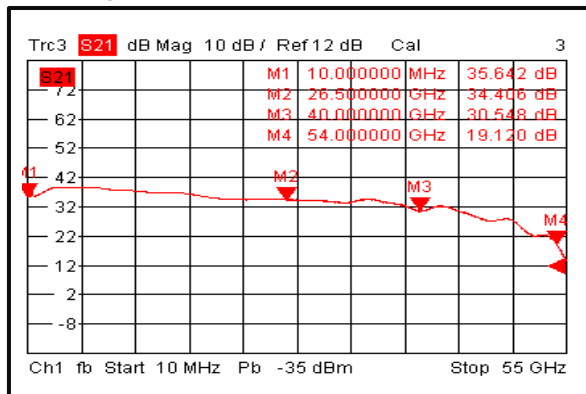

### Input VSWR @ -40°C

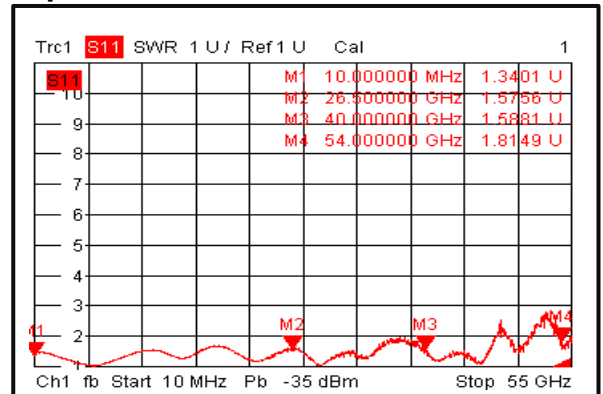

### Output VSWR @ -40°C

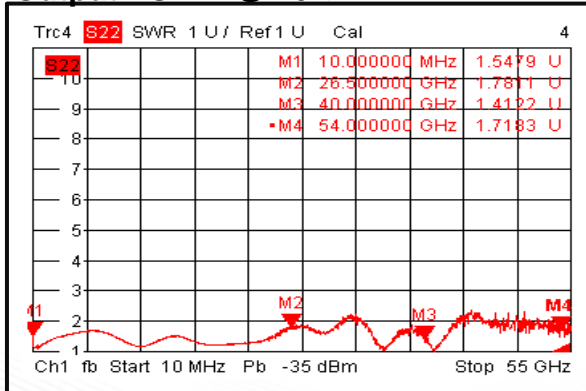

### Isolation @ -40°C

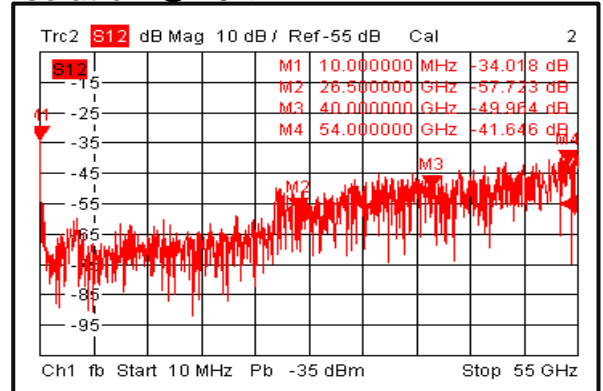



### Gain @ +85°C

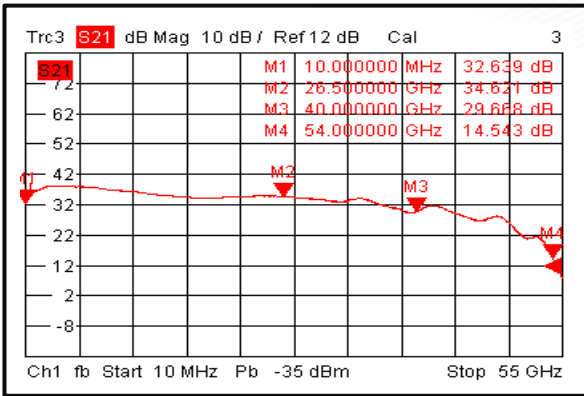

### Input VSWR @ +85°C

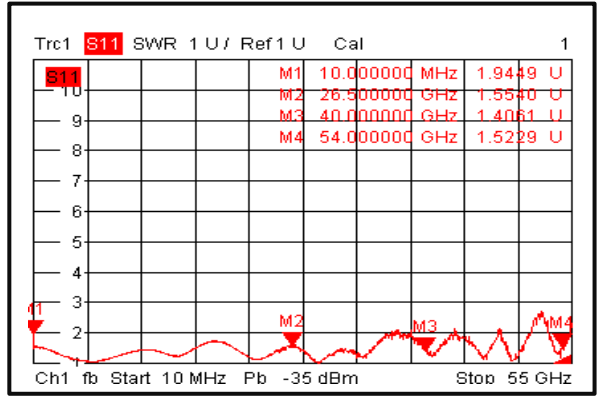

### Output VSWR @ +85°C

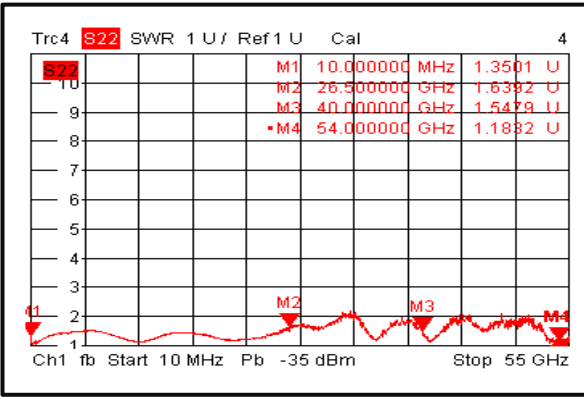

### Isolation @ +85°C

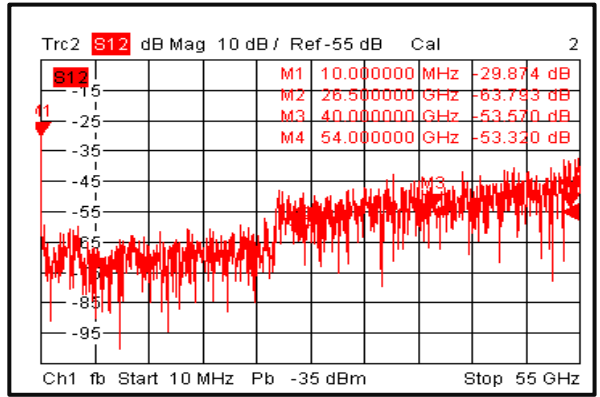

### Gain vs. Output Power

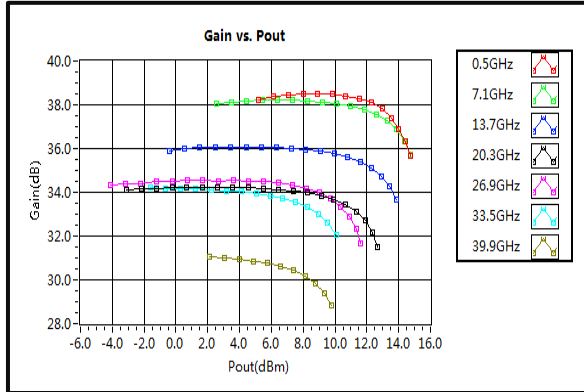

### P1dB vs. Frequency

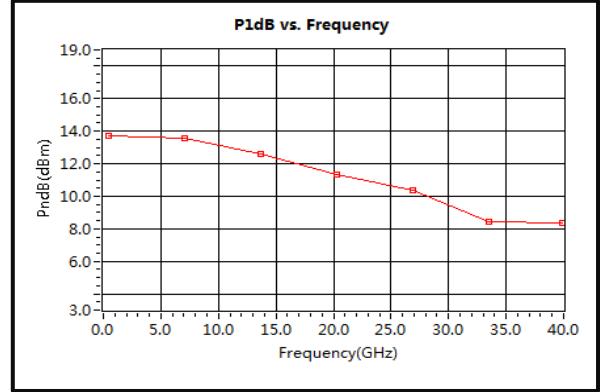

### Output Third Order Intercept (OIP3)

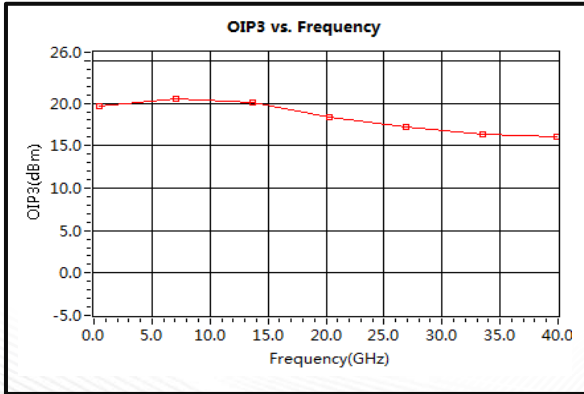

### Noise Figure

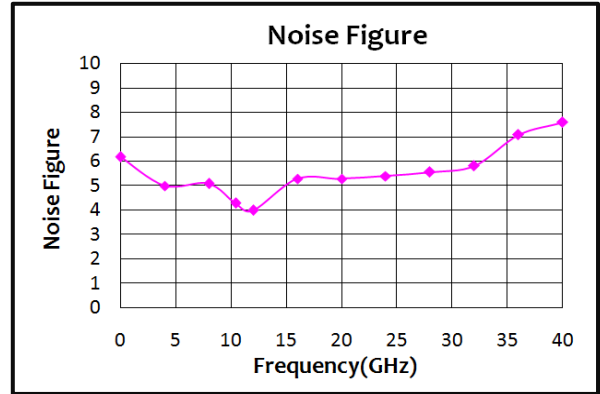



## 2nd Harmonic Wave Output Power

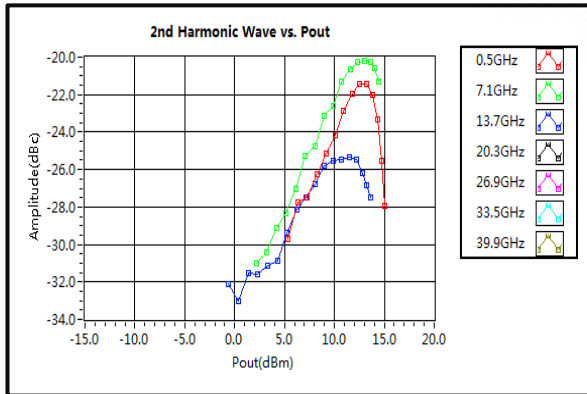

## 3rd Harmonic Wave Output Power

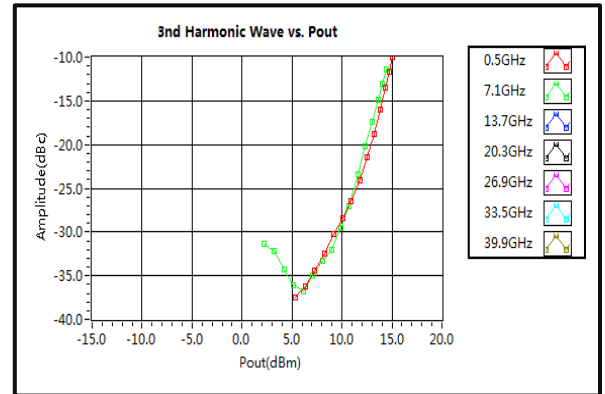

## 4th Harmonic Wave Output Power

